

REAR PANEL DRILLING DETAILS (SHOWN HERE AT 50% OF FULL SIZE) ALL HOLES ARE 10mm DIAMETER

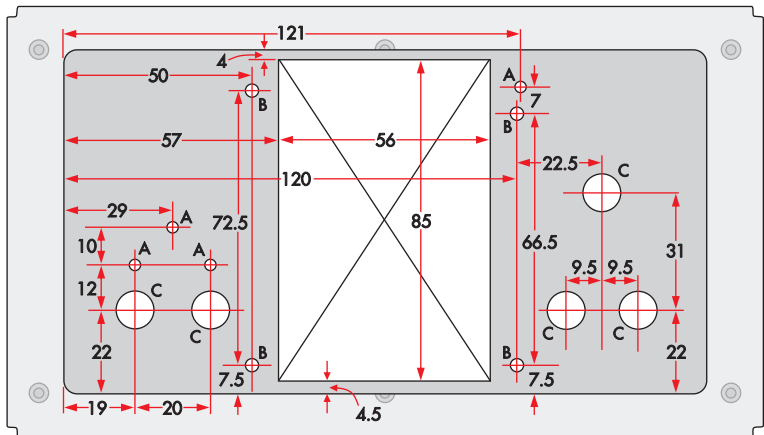

HOLES A: 3.0mm DIAMETER; HOLES B: 3.5mm DIAMETER; HOLES C: 10mm DIAMETER

CASE LID/FRONT PANEL DRILLING & CUTTING DETAILS (SHOWN HERE AT 50% OF FULL SIZE)

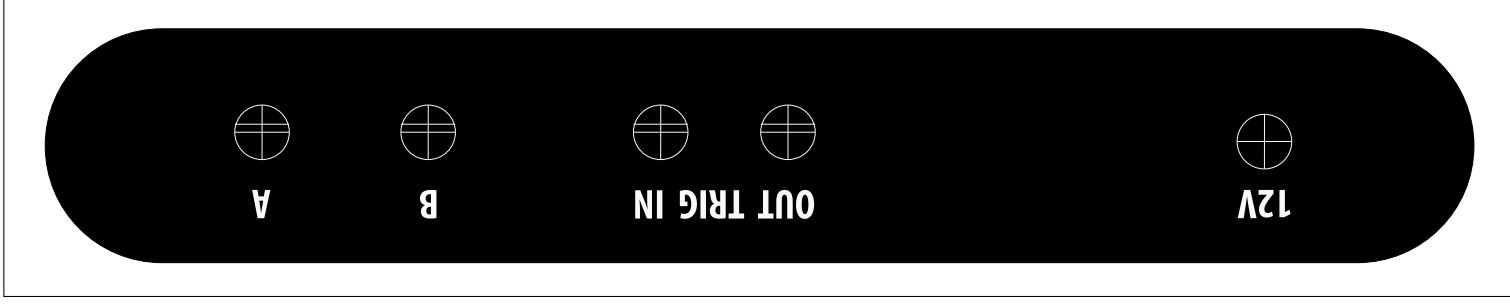

Bounding rectangles:

Back 200 x 40mm (outer) 189 x 31 (rounded)

Top 200 x 113mm (outer) 171 x 93.5 mm (rounded)